

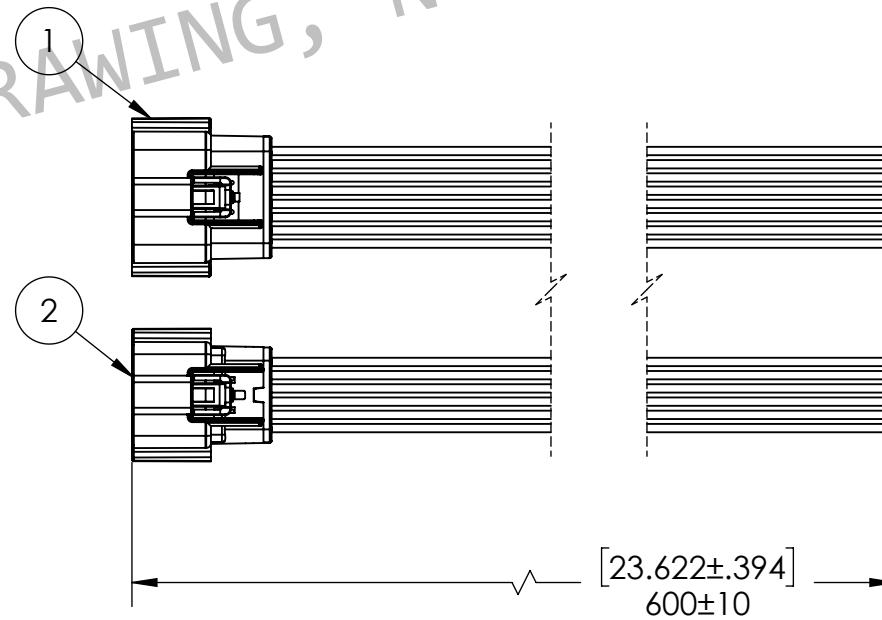

ITEM NO.	QTY.	PART NUMBER	DESCRIPTION	MANUFACTURER	MANUFACTURER P/N
1	1	42-000402	MX150, PLUG, 16 PIN, FEMALE	MOLEX	0334721601
2	1	42-000400	MX150, PLUG, 6 PIN, SINGLE ROW, FEMALE	MOLEX 33471-0601 or equiv.	33471-0601
3	22	42-000334	MX150 Female pin 18-20AWG	MOLEX	33012-2002

REVISIONS			
ZONE	REV.	DESCRIPTION	DATE
	X-01	Release for quote	2020-06-25

42-000402	Colour
1	PINK
2	BLUE/WHITE
3	YELLOW/WHITE
4	WHITE/GREEN
5	BLUE/BLACK
6	ORANGE
7	PURPLE
8	WHITE/GREEN
9	RED/WHITE
10	GREY/BLACK
11	YELLOW/BLACK
12	PURPLE/WHITE
13	GREY/WHITE
14	BLACK
15	BLACK
16	WHITE/BLACK
42-000400	
1	WHITE
2	BLACK
3	GREEN
4	YELLOW
5	BLUE
6	ORANGE/WHITE

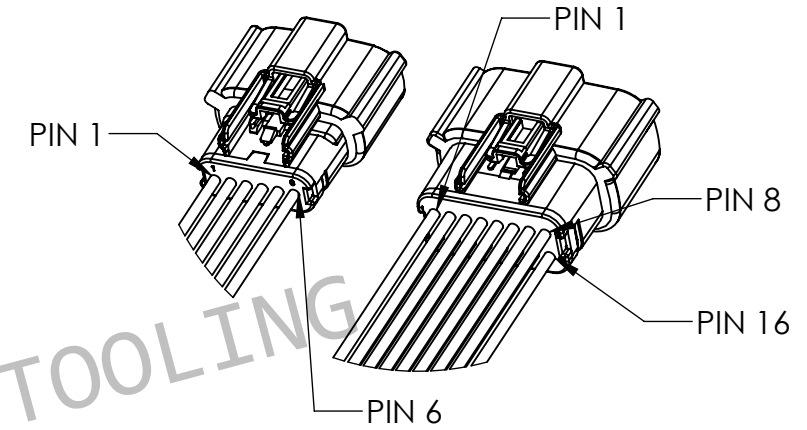

- WIRE:
- TEMPERATURE RATING: 105C MINIMUM
 - VOLTAGE RATING: 150V MINIMUM
 - ALL MATERIAL VW-1 IN ACCORDANCE WITH UL 1581
 - ALL MATERIAL MUST BE RoHS 3
 - GAUGE: 18 AWG
 - COLOUR ACCORDING TO TABLE ABOVE

UNLESS OTHERWISE SPECIFIED: DIMENSIONS ARE IN MM TOLERANCES: .X ± 0.5 .XX ± 0.1 .XX ± 0.05 .XXX ± 0.01	PROPRIETARY AND CONFIDENTIAL THE INFORMATION CONTAINED IN THIS DRAWING IS THE SOLE PROPERTY OF ACCELERATED SYSTEMS INC. ANY REPRODUCTION IN PART OR AS A WHOLE WITHOUT THE WRITTEN PERMISSION OF ACCELERATED SYSTEMS INC. IS PROHIBITED.		DWG#: 44-000025	
	DRAWN kflannigan 2020-06-25		TITLE: BAC MX150 HARNESS - NO CONNECTORS	
MATERIAL	REVISED kflannigan 2020-06-25	SIZE B  ACCELERATED SYSTEMS INC.		REV X-01
FINISH	CHECKED kflannigan 2020-06-25	SCALE: 1:1 WEIGHT:		SHEET 1 OF 1